

The JBL logo is displayed in white, bold, sans-serif capital letters within a solid orange square. The logo consists of the letters 'JBL' with a stylized 'J' that has a dot above it.

PROFESSIONAL

**VTX SERIES**  
SYSTEM SOLUTIONS

## VTX B28 | User Manual



## **GENERAL INFORMATION**

VTX B28 User Manual

Document Number: 1000346379

Version: B - EN

Distribution Date: December 3, 2020

Copyright © 2020 by HARMAN International; all rights reserved

## **JBL PROFESSIONAL**

8500 Balboa Blvd

Northridge, CA 91329

USA

Thank you for purchasing JBL VTX Series products



In more than 75 years of JBL innovations, the VTX Series stands apart as a milestone in the practical application of creative engineering. VTX products herald the next generation in line array loudspeaker systems: a new era in performance, system integration and user friendliness. VTX products draw on multiple JBL patents in driver, waveguide, and suspension technology, as well as custom amplification, DSP, control, and system management designs created in collaboration with HARMAN Professional sister companies.

VTX loudspeakers marry custom transducer design and in-house manufacture, breakthrough technologies, and a comprehensive system approach to deliver a premium experience for all who come into contact with it, from the FOH mixing engineer to the systems engineer, rigger, road crew, warehouse manager, and, of course, the audience. Designed for operators of portable and fixed systems alike, the VTX Series features JBL's legendary sound quality coupled with expert support and advanced tools that enable optimal specification, configuration, and operation of VTX systems in any venue, anywhere in the world. The VTX Series delivers a comprehensive solution: the finest sound quality available, plus efficient and intuitive setup, tuning, networking, and control.

## TABLE OF CONTENTS

<b>1 - SAFETY</b> .....	<b>6</b>
1.1 Safety Instructions .....	6
1.2 General Hardware Information .....	6
1.3 Attachment to Structures .....	6
1.4 Important Safety Warning .....	7
1.5 Are You New to Rigging? .....	7
1.6 Inspection and Maintenance .....	7
1.7 Symbols .....	8
<b>2 - SYSTEM COMPONENTS</b> .....	<b>9</b>
<b>3 - COMPATIBLE ACCESSORIES</b> .....	<b>10</b>
3.1 VTX B28 SB - Suspension Bar .....	10
3.2 VTX B28 VT - Vertical Transporter .....	10
3.3 VTX B28 VT CVR - Soft Cover .....	10
3.4 VTX B28 ACC - Accessory Cover and Caster Board .....	11
3.5 VTX B28 GND Ground Stack Accessory .....	11
<b>4 - SOFTWARE</b> .....	<b>12</b>
4.1 Line Array Calculator 3™ .....	12
4.2 Array Link™ .....	12
4.3 Performance Manager™ .....	12
<b>5 - OVERVIEW</b> .....	<b>13</b>
<b>6 - CONNECTIONS</b> .....	<b>14</b>
6.1 Internal Wiring .....	14
<b>7 - TRANSPORTATION OPTIONS</b> .....	<b>15</b>
7.1 Rotating the Dolly Tabs For Use With the ACC Dolly .....	16
<b>8 - VTX B28 PRESET LIBRARY</b> .....	<b>17</b>
8.1 VTX B28 Preset Modes and Options .....	17
8.2 Time Alignment .....	17
8.3 Product Line Compatibility .....	17
<b>9 - SYSTEM AMPLIFICATION &amp; WIRING</b> .....	<b>18</b>
9.1 B28 Using Crown I-Tech 12000HD .....	18
9.2 B28 Using I-Tech 4x3500HD .....	19
9.3 Crown V-Rack .....	20
<b>10 - CARDIOID CONFIGURATIONS</b> .....	<b>21</b>
10.1 Recommended Cardioid Setups .....	22

- 10.2 Minimum Space Between Cardioid Stacks ..... 23
- 10.3 Minimum Space from a Wall ..... 24
- 10.4 Flown Array Configurations ..... 25
- 11 - CAROID PRESETS IN PERFORMANCE MANAGER ..... 26**
- 12 - TESTING THE VTX B28 ..... 27**
  - 12.1 Using a DMM (Digital Multi meter) ..... 27
  - 12.2 Using Performance Manager ..... 28
  - 12.3 Performance Manager Readings ..... 28
- 13 - SPECIFICATIONS ..... 29**
  - 13.1 VTX B28 ..... 29
- 14 - ACOUSTIC MEASUREMENTS ..... 30**
- 15 - DIMENSIONS ..... 30**
- 16 - CONTACT INFORMATION ..... 31**

## 1 - SAFETY

### 1.1 SAFETY INSTRUCTIONS

1. Read these instructions.
2. Keep these instructions.
3. Heed all warnings.
4. Follow all instructions.
5. Do not expose the product to direct rain or sea spray.
6. Clean only with a dry cloth.
7. Do not install near any heat sources such as radiators, heat registers, stoves, or other apparatus that produce heat.
8. Only use attachments/accessories specified by the manufacturer.
9. Use only with a cart, stand, tripod, bracket, or table specified by the manufacturer or sold with the apparatus. When a cart is used, use caution when moving the cart/apparatus combination to avoid injury from tip-over.
10. Refer all servicing to qualified service personnel. Servicing is required when the apparatus has been damaged in any way, such as if liquid has been spilled or objects have fallen into the apparatus, or if the apparatus has been exposed to rain or moisture, does not operate normally, or has been dropped.
11. Contact JBL Professional for advanced servicing issues.
12. **CAUTION - DO NOT PERFORM ANY SERVICING UNLESS YOU ARE QUALIFIED TO DO SO.**
13. Prolonged exposure to excessive SPL can cause hearing damage. The loudspeaker is easily capable of generating sound pressure levels (SPL) sufficient to cause permanent hearing damage to performers, production crew, and audience members. Caution should be taken to avoid prolonged exposure to SPL in excess of 90 dB.
14. Read the System Rigging Manual before installation and use of the product.

### 1.2 GENERAL HARDWARE INFORMATION

Any hardware used in an overhead suspension application must be load rated for the intended use. Generally, this type of hardware is available from rigging supply houses, industrial supply catalogs, and specialized rigging distributors. Local hardware stores do not usually stock these products. Compliant hardware will be referenced with a working load limit (WLL) and a traceability code.

### 1.3 ATTACHMENT TO STRUCTURES

A licensed Professional Engineer must approve the placement and method of attachment to the structure prior to the installation of any overhead object. The following performance standards should be provided to the Professional Engineer for design purposes: Uniform Building Code as applicable, Municipal Building Code as applicable, and Seismic Code as applicable. The installation of the hardware and method of attachment must be carried out in the manner specified by the Professional Engineer. Improper installation may result in damage, injury, or death.

## 1.4 IMPORTANT SAFETY WARNING

The information in this section has been assembled from recognized engineering data and is intended for informational purposes only. None of the information in this section should be used without first obtaining competent advice with respect to applicability to a given circumstance. None of the information presented herein is intended as a representation or warranty on the part of JBL. Anyone making use of this information assumes all liability arising from such use.

All information presented herein is based upon materials and practices common to North America and may not directly apply to other countries because of differing material dimensions, specifications, and/or local regulations. Users in other countries should consult with appropriate engineering and regulatory authorities for specific guidelines.

Correct use of all included hardware is required for secure system suspension. Careful calculations should always be performed to ensure that all components are used within their working load limits before the array is suspended. Never exceed the maximum recommended load ratings.

Before suspending any speaker system, always inspect all components (enclosure, rigging frames, pins, eyebolts, track fittings, etc.) for cracks, deformations, corrosion, or missing/loose/damaged parts that could reduce strength and safety of the array. Do not suspend the speaker until the proper corrective action has been taken. Use only load-rated hardware when suspending JBL suspendable loudspeaker models.

## 1.5 ARE YOU NEW TO RIGGING?

**If you are new to rigging, you should:**

- Know the rules for safe rigging.
- Attend a safe rigging seminar.
- Meet and establish a relationship with a licensed mechanical or structural engineer. Get in the habit of asking them questions instead of assuming their answers. Learn from what they tell you.
- Research and understand the codes, practices and requirements of the venues where you intend to operate your sound system.

## 1.6 INSPECTION AND MAINTENANCE

Suspension systems are comprised of mechanical devices and, as such, require regular inspection and routine maintenance to ensure proper functionality. Before suspending or pole mounting any speaker system, always inspect all components (enclosure, suspension frames or brackets, pins, eyebolts, etc.) for cracks, deformations, corrosion, or missing/loose/damaged parts that could reduce strength and safety of the array. Do not suspend or pole mount a speaker until the proper corrective action has been taken.

Installed systems should be inspected at least once a year. The inspection must include a visual survey of all corners and load-bearing surfaces for signs of cracking, water damage, delamination, or any other condition that may decrease the strength of the loudspeaker enclosure.

Accessory suspension hardware provided with or for VTX systems must be inspected for fatigue at least once a year or as required by local ordinance. The inspection must include a visual survey of the material for signs of corrosion, bending, or any other condition that may decrease the strength of the fastener. Additionally, any eyebolts must be checked for possible spin-out of the enclosure.

**For all other hardware and fittings, refer to the hardware manufacturer's inspection and maintenance guidelines for process.**

JBL is not responsible for the application of its products for any purpose or the misuse of this information for any purpose. Furthermore, JBL is not responsible for the abuse of its products caused by avoiding compliance with inspection and maintenance procedures or any other abuse.

Prior to suspending the system, an expert, trained and experienced in suspending speaker systems, should inspect all parts and components.

## 1.7 SYMBOLS

The following symbols are used in this document:



**CAUTION:** This symbol gives notice of a potential risk of harm to the individual or the equipment. Instruction marked with this symbol must be strictly followed.



**TIP:** This symbol gives notice of helpful, relevant information about the topic.



**INSTRUCTIONS:** This symbol gives notice of instructions that must be followed for proper installation and use of the product.



**TOOLS REQUIRED:** This symbol gives notice of tools that must be used for proper installation and use of the product.



## 2 - SYSTEM COMPONENTS

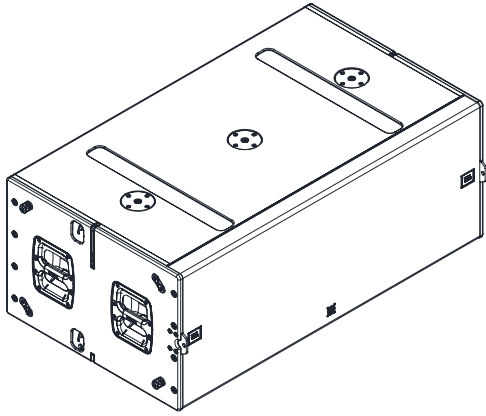

**VTX B28**

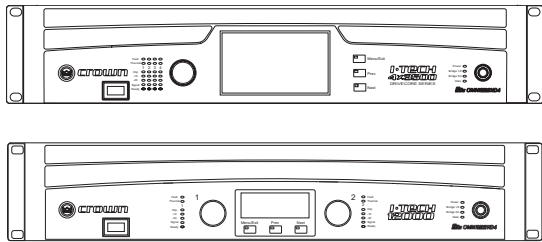

**Crown I-Tech HD Amplifiers**

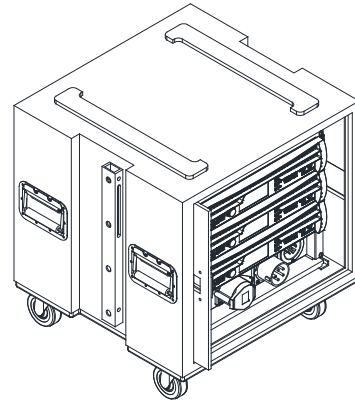

**Crown V-Rack**

### 3 - COMPATIBLE ACCESSORIES

The accessories listed below are compatible with the VTX B28. For more detailed information about the B28 accessories refer to the VTX B28 Rigging Manual found at [www.jblpro.com](http://www.jblpro.com).

#### 3.1 VTX B28 SB - SUSPENSION BAR

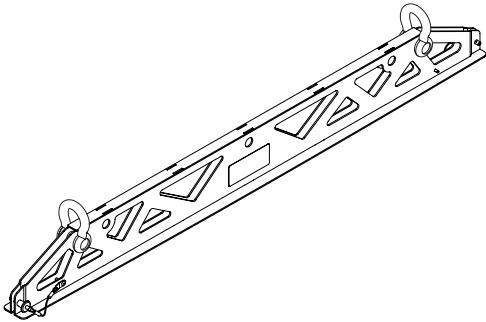

- Versatile suspension bar accessory for B28 subwoofer
- Single-point and dual-point support
- Secondary safety attachment points included
- Support for (16) B28 enclosures
- Lightweight, fully symmetric design
- Shackle Size: 5/8 inch

#### 3.2 VTX B28 VT - VERTICAL TRANSPORTER

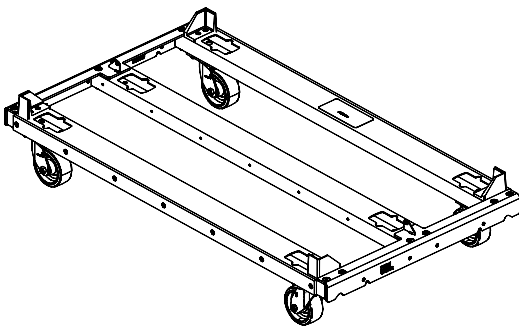

- Vertical transport cart for up to four VTX B28 enclosures
- Truck-friendly dimensions
- Built-in stacking features for easy storage
- Lightweight aluminum design
- Heavy-duty four-grade casters
- Compatible with the VTX A12 VT GND

#### 3.3 VTX B28 VT CVR - SOFT COVER

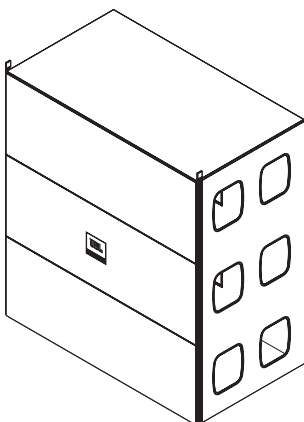

- Heavy-duty soft cover for VTX B28 stacks
- Covers three or four VTX B28 enclosures
- Includes input-panel flaps for testing purposes
- Clear see-through pocket for shipping labels
- Handle cutouts for easy transportation
- Heavy-duty industrial-grade zippers
- Foldable design for storage

### 3.4 VTX B28 ACC - ACCESSORY COVER AND CASTER BOARD

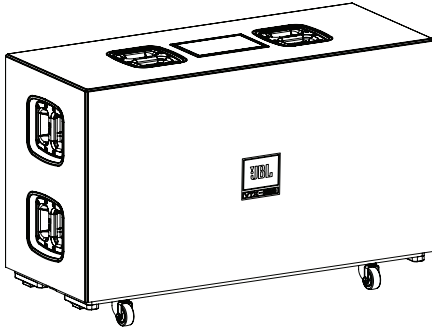

- Transportation kit for VTX B28
- Includes protective cover and caster board
- Handle cutouts and rear panel access flap
- Tour-grade casters
- Stackable for convenient storage
- Rotating locking cam mechanisms for secure attachment to B28 enclosures

### 3.5 VTX B28 GND GROUND STACK ACCESSORY

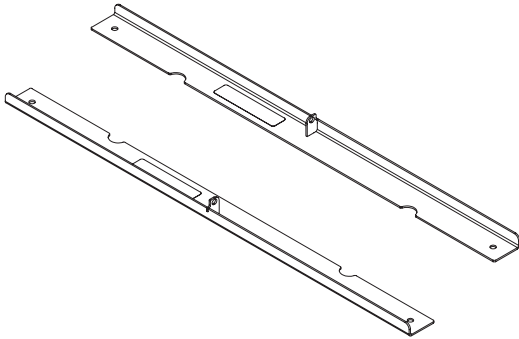

- Improves stability of ground stacks built on the B28 subwoofer
- Attaches directly to B28 integral rigging
- Simple two-part design
- Lightweight



**CAUTION:** Always use components and accessories specified and approved by JBL Professional. When a cart is used, use caution when moving the cart to avoid injury from tip-over.

## 4 - SOFTWARE

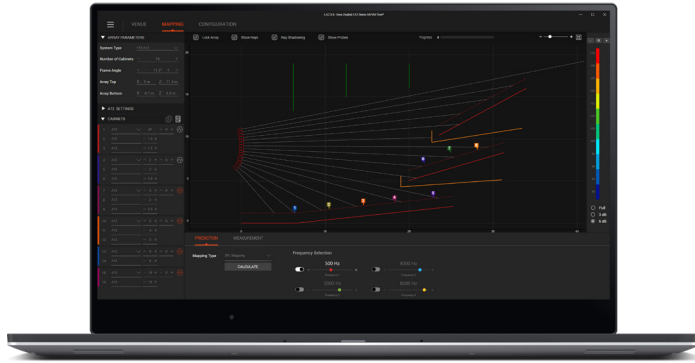

### 4.1 LINE ARRAY CALCULATOR 3™

LAC is simulation software for designing and predicting VTX Series systems. LAC predicts the acoustical performance of line array systems, as well as flown and ground-stacked subwoofer arrays. Subwoofer delay values can be generated for electronic delay steering (EDS) using the built-in coverage calculator. LAC also performs mechanical validation of rigging hardware, calculates weight limits, and generates safety warnings.

[www.jblpro.com/lac3](http://www.jblpro.com/lac3)

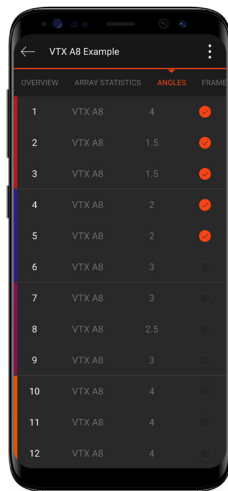

### 4.2 ARRAY LINK™

Array Link™ is a mobile companion app that works in conjunction with LAC software to assist in deployment of VTX Series systems. Array Link uses a QR code system to transfer all mechanical array information from the main LAC application to a mobile phone. All relevant rigging and mechanical options are presented in an easy-to-understand layout. The application is compatible with iOS® and Android™ and can be obtained from their respective app stores.

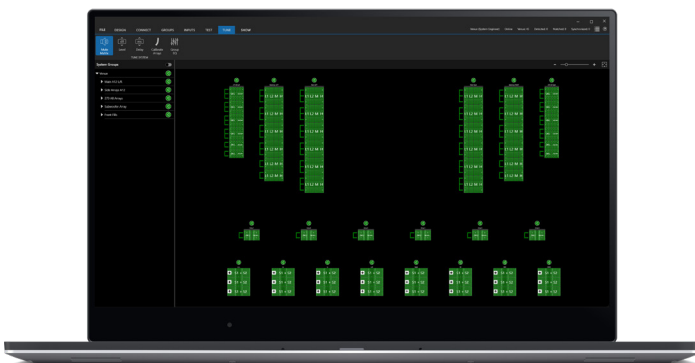

### 4.3 PERFORMANCE MANAGER™

Performance Manager™ is a configuration and control application for networked audio systems. Performance Manager's user interface guides system designers through the complete system design, configuration, and control processes. A dedicated show mode provides all monitoring and control functions needed to deliver a complete picture of the system's performance in real time.

[www.jblpro.com/performancemanager](http://www.jblpro.com/performancemanager)

## 5 - OVERVIEW

The VTX B28 is JBL Professional's next-generation dual 18-inch subwoofer, designed to complement the company's flagship VTX full-range sound reinforcement systems. The VTX B28 features two JBL 2288H-M 18-inch woofers engineered for improved linearity, efficiency, and extra-long excursion. The 2288M employs Differential Drive – JBL's dual voice coil, dual gap technology – to deliver better heat dissipation, lower power compression, and wider dynamic range than conventional single-coil designs. The B28 incorporates a double-flared, exponential, low frequency port design to improve airflow and reduce audible turbulence, even at high output levels.



The B28 shares the industrial design of the VTX A-Series products, and features an innovative and simple-to-use two-point rigging system. The all-captive rigging system utilizes a spring-loaded mechanism to deploy the link bars and a unique locking system that complies with all safety requirements without using traditional quick release pins. B28 subwoofers can be deployed in omnidirectional or cardioid arrays, ground stacked, or in suspended configurations of up to 16 enclosures.

---

### RIGGING SYSTEM

The B28 uses a simple and innovative two-point rigging system capable of suspending arrays of up to 16 B28 enclosures. Rigging components are hidden behind the two wooden side panels, and the two link bars are deployed by a spring-loaded mechanism. A unique, all-captive locking system secures cabinets together using a set of levers and sliding pins. The mechanism includes a safety lock to prevent unintentional release, and complies with all safety requirements. When B28 cabinets are ground stacked, the all-captive design keeps unused parts hidden and damped from rattling.

### CONTROLLABLE COVERAGE

The B28 makes it simple to form omnidirectional or cardioid arrays. Speaker connectors are available on both front and rear panels, streamlining cable management in either configuration.

### SYSTEM SOLUTION

The VTX Series is a comprehensive family of hardware and software products and accessories that work together to facilitate the complete event workflow, from system design to transport home. Tools support tasks every step of the way.

### PERFORMANCE

The 2288H-M 18-inch woofers are engineered from the ground up to deliver transparent, linear bass response down to 25 Hz. This driver leverages JBL's patented, fourth-generation, Differential Drive technology to deliver maximum sensitivity and power handling in a light, compact design. The B28 is intended to provide accurate very low frequency coverage adequate for the most demanding applications.

## 6 - CONNECTIONS

The VTX B28 is equipped with two Neutrik NL4 speakON connectors, one on the rear of the cabinet and one on the front. The 18-inch woofers inside the B28 are wired in parallel from pins 1+/1- of the NL4 connectors. Since this results in a nominal load of 4 ohms, daisy-chaining subwoofers is not recommended. The NL4 connector on the front is typically used in cardioid configurations, where some enclosures are pointed rearwards, to keep the cable run on the back of the array. All NL4 connectors are installed upside down so that the NL4 locking pin position can be seen from under the array.

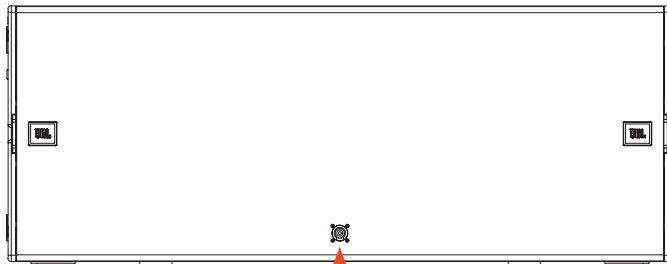

Front NL4 Connector

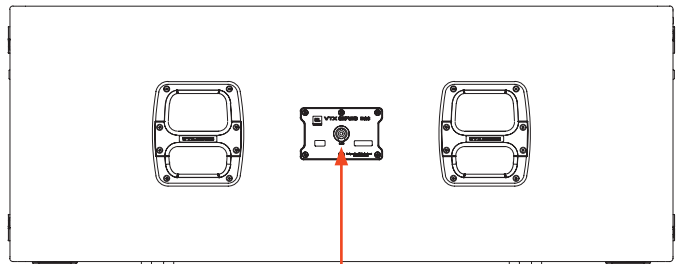

Rear NL4 Connector

### 6.1 INTERNAL WIRING

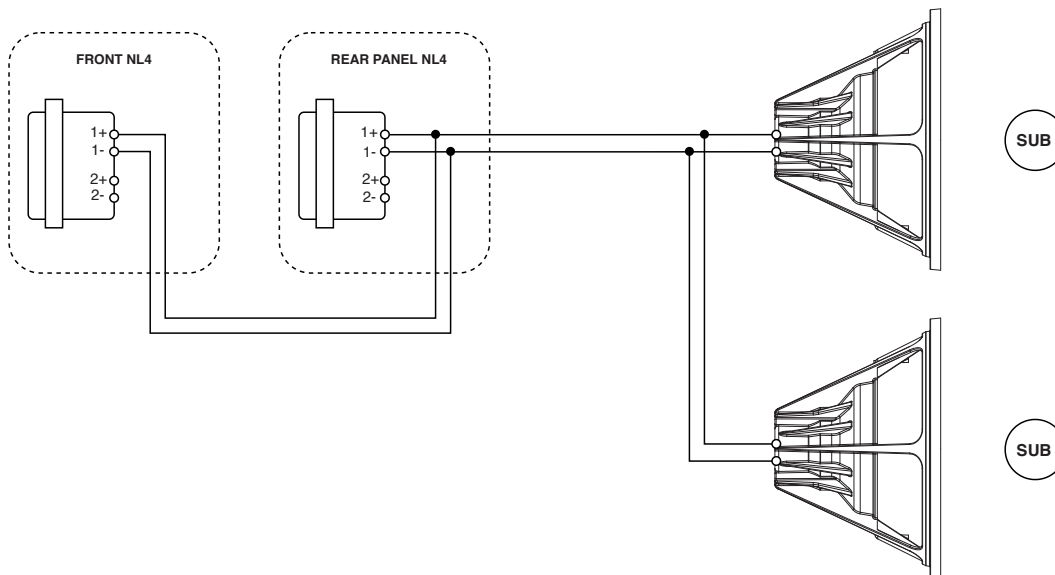

**CAUTION:** Always use high-quality insulated speaker cables made by reputable manufacturers. Keep cable length as short as possible with a sufficient wire gauge for the application.

## 7 - TRANSPORTATION OPTIONS

B28 subwoofers can be transported singly or in stacks. The VTX B28 VT Vertical Transporter cart allows transporting stacks of up to four B28 subwoofers. When stacked in blocks of two, three, or four, B28 cabinets can be transported in either front-firing or cardioid configurations. The VTX B28 VT CVR, a reinforced cover, is available for protecting subwoofers during transportation. The VT option is ideal for large-scale touring situations where large format trucks are used and maximum deployment efficiency is needed. Single B28 cabinets can be transported using the VTX B28 ACC accessory kit, which includes a front-face dolly and a protective cover. The ACC option is more agile and efficient for transportation, as it allows stacking B28 subwoofers on top of other equipment in the trucks.

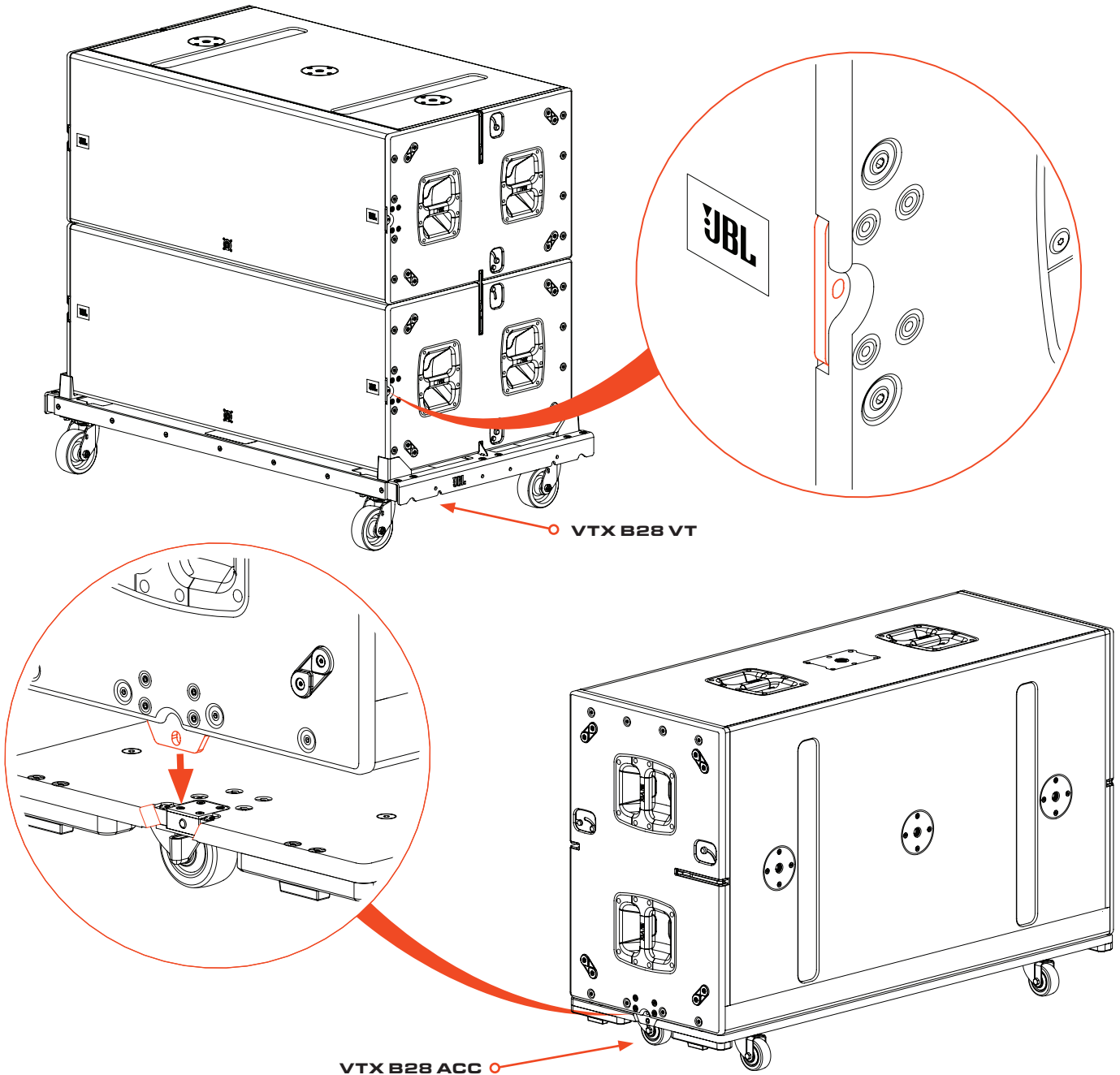

**TIP:** For additional information on how to use and deploy the ACC and Vertical Transporter refer to the VTX B28 Rigging Manual, which can be downloaded from the JBL Professional website.

## 7.1 ROTATING THE DOLLY TABS FOR USE WITH THE ACC DOLLY

Two dolly tabs at the front of the B28 are used to secure the front-face ACC dolly board to the B28. The tabs are retractable and ship from the factory in the retracted position inside the B28. This orientation is ideal when B28s are on a vertical transport cart, where the tabs are not needed, but the tabs must be rotated to attach a front-face dolly board to the B28.

### STEPS:

- 1 Remove the four M6 HEX bolts holding the bracket onto the B28.
- 2 Rotate the bracket to the extended position.
- 3 Install the bolts.
- 4 Repeat for the other side.

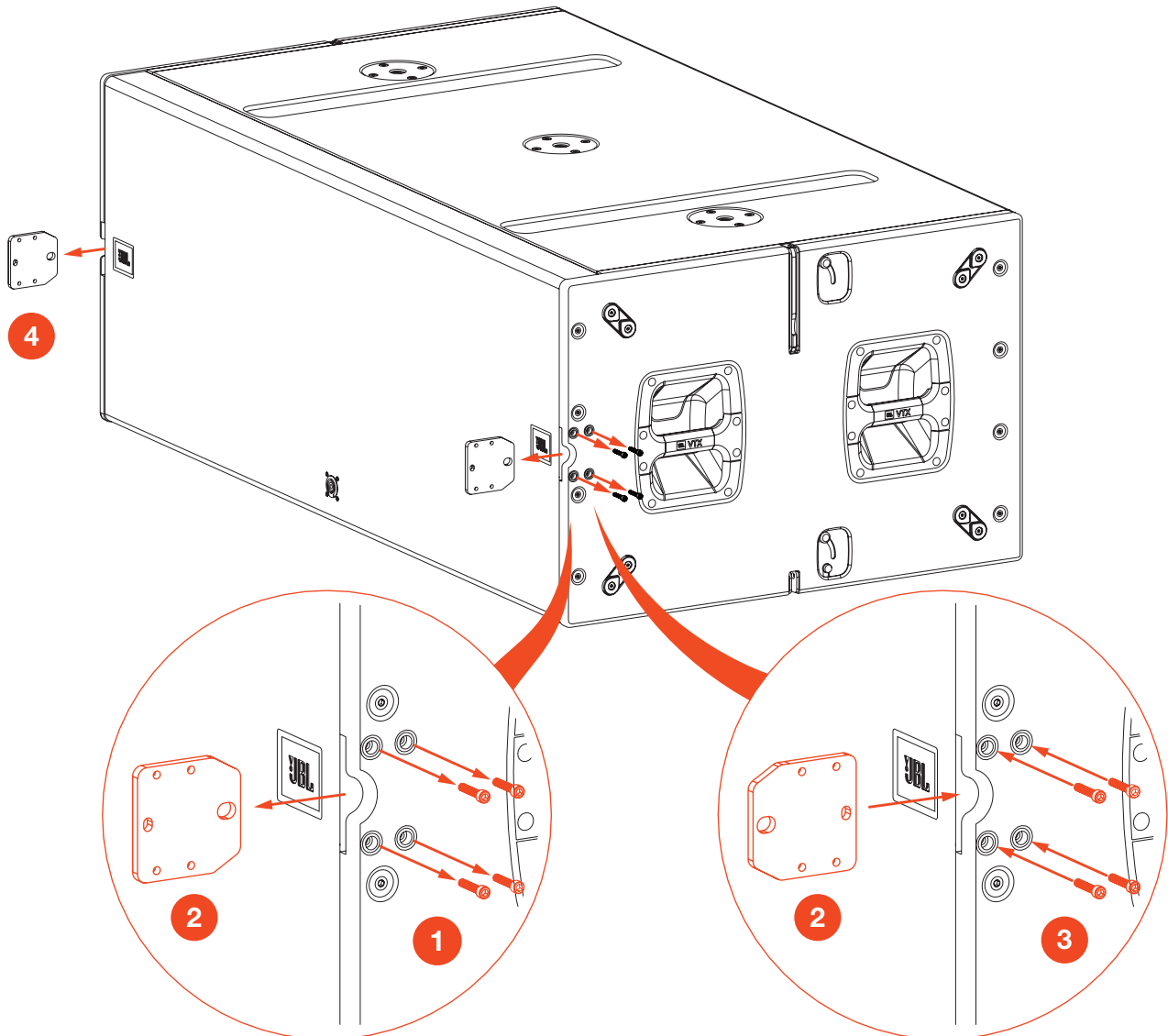

**TOOLS REQUIRED:** A Torx T25 wrench is required to remove the four bolts holding the ACC brackets. All bolts should be torqued to 2.82 N.m (25 in.lbs).



## 8 - VTX B28 PRESET LIBRARY

The VTX B28 preset library includes 60 and 80 Hz operating modes along with cardioid presets for rear-facing subwoofer enclosures. VTX presets are exclusively developed for Crown I-Tech HD amplifiers and come bundled with Performance Manager™ control software. Audio Architect presets are also available and can be downloaded from the JBL Pro website. See below for a detailed description of the B28 operating modes and processing options, and refer to the Preset Library setup sheets for preset descriptions, memory locations and output channel assignments.

### 8.1 VTX B28 PRESET MODES AND OPTIONS

**VTX B28 60:** The 60 Hz preset mode extends the upper frequency response of the B28 to 60 Hz. The B28 60 preset is normally used when VTX full-range cabinets, such as the A8 or A12, are used in full-range mode and minimal overlap between the subwoofers and full-range cabinets is desirable.

**VTX B28 60 REAR:** The 60 Hz Rear preset is designed to perform the same function as the standard B28 60 preset for rear-facing B28 cabinets in cardioid configurations.

**VTX B28 80:** The 80 Hz preset mode extends the upper frequency response of the B28 to 80 Hz. The 80 Hz preset is normally used when VTX full-range cabinets, such as the VTX A8 or A12, are set to an 80 Hz cutoff.

**VTX B28 80 REAR:** The 80 Hz Rear preset is designed to perform the same function as the standard B28 80 preset for rear-facing B28 cabinets in cardioid configurations.

### 8.2 TIME ALIGNMENT

The VTX B28 presets provide proper system summation with companion VTX full-range cabinets (all models) in physically coupled configurations (stacked or suspended), and when used with corresponding 60 or 80 Hz presets. This pre-alignment is done at the factory, allowing any VTX subwoofer to be used with any VTX loudspeaker without subwoofer presets specific to each system and configuration. Additional time alignment delay should be added as needed to account for physical path length differences between suspended full-range arrays and ground-stacked VTX subwoofers.

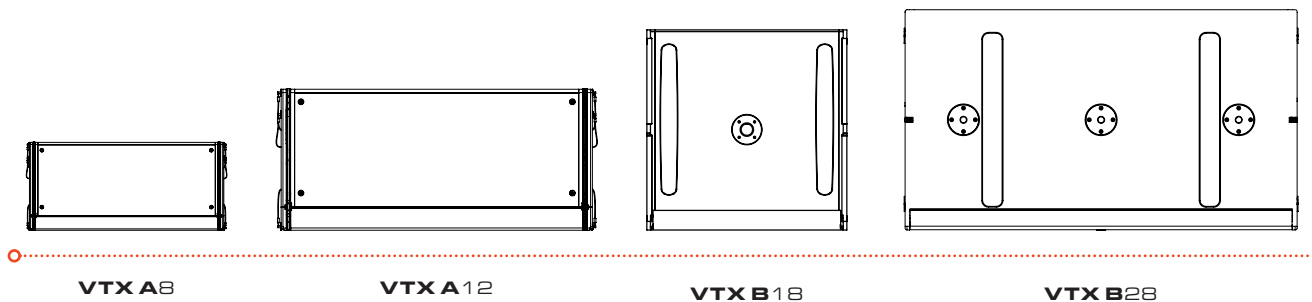

### 8.3 PRODUCT LINE COMPATIBILITY

The VTX B28 acoustical characteristics are compatible with those of the VTX B18. VTX B28 and B18 can be combined together in the same system or array without summation problems. In arrays combining the B28 and B18 (or any other VTX subwoofer), all subwoofers should be operated in the same mode. Mixing 60 Hz and 80 Hz presets in the same system or array is not recommended.

## 9 - SYSTEM AMPLIFICATION & WIRING

The VTX B28 subwoofer, like all other VTX systems, is powered exclusively by Crown I-Tech HD amplifiers, providing consistency and optimum performance anywhere in the world. All B28 processing is performed using the I-Tech HD's internal processing, which includes the advanced LevelMax™ three-stage limiter suite, ensuring proper, reliable B28 operation under any conditions. LevelMax incorporates excursion control, RMS limiting, and long-term thermal protection for the woofers. The I-Tech HD amplifiers also offer a user-adjustable input section for equalization, time alignment, and electronic delay steering. Standard JBL presets are available for both the Crown I-Tech 4x3500HD and I-Tech 12000HD. The most up-to-date presets are available for download from [www.jblpro.com](http://www.jblpro.com), and bundled in the latest version of Performance Manager™ control software.

### 9.1 B28 USING CROWN I-TECH 12000HD

The Crown I-Tech 12000HD is the recommended amplifier for powering VTX B28 subwoofers. Two VTX B28 subwoofers (one per channel) can be powered by each amplifier. The example below shows how to connect two VTX B28 cabinets to a two-channel I-Tech HD amplifier using two standard NL4 (or NL2) cables.

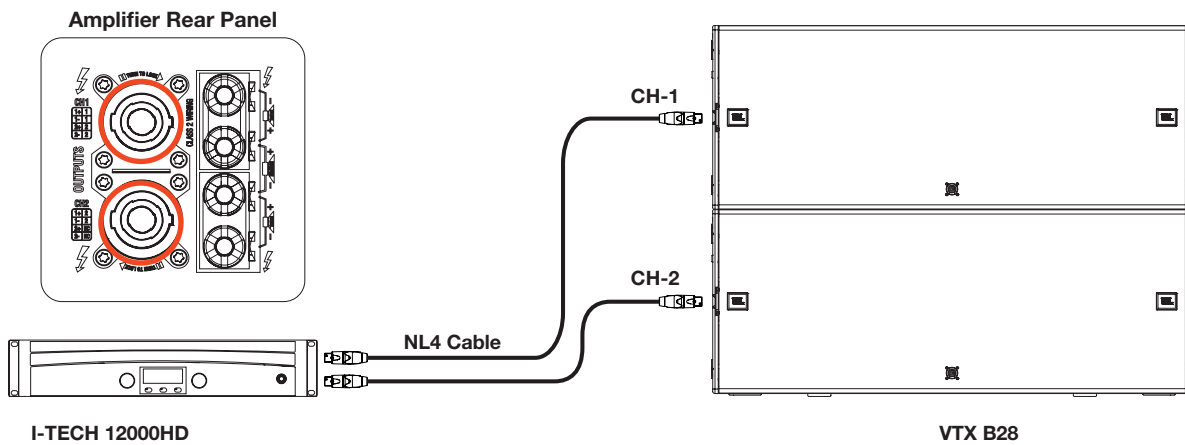

Alternatively, a cable splitting an NL4 to two NL2 connectors can be used, which allows connecting a pair of B28 subwoofers using a single four-conductor NL4 cable. This can reduce cabling requirements by a factor of two. **The NL4 connector for channel A on the amplifier must be used in this configuration, as it carries both channel signals, while the channel B connector does not.**

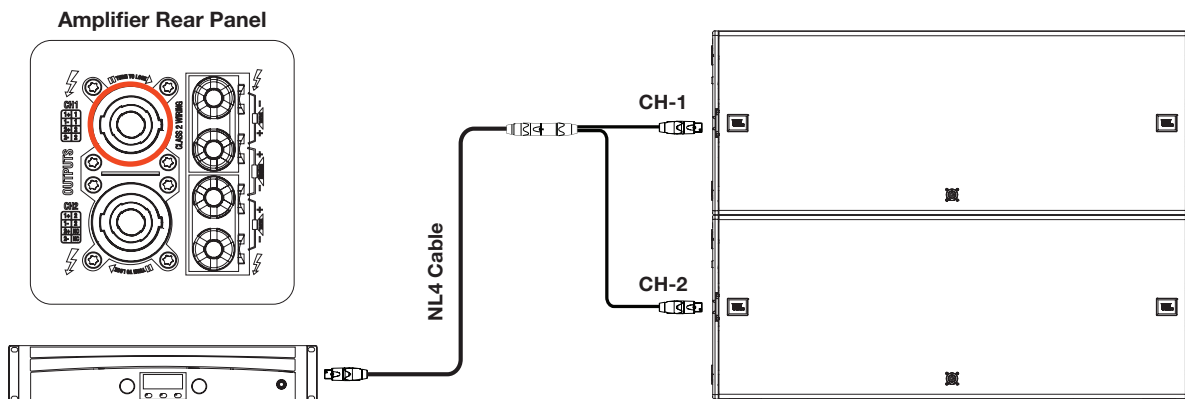

### 9.2 B28 USING I-TECH 4X3500HD

When using Crown I-Tech 4x3500HD amplifiers, up to two VTX B28 subwoofers can be powered per amplifier and the remaining channels can be used to power a JBL full-range speaker, such as the VTX A8. The example below illustrates how to connect two VTX B28 cabinets to a four-channel I-Tech HD amplifier using standard NL4 (or NL2) cables. In the example below, the two subwoofers are connected to amplifier channels 1 and 3 using the two NL4 output connectors. Channels 2 and 4 are available and, with an NL8 connector, can be used to power other speakers.

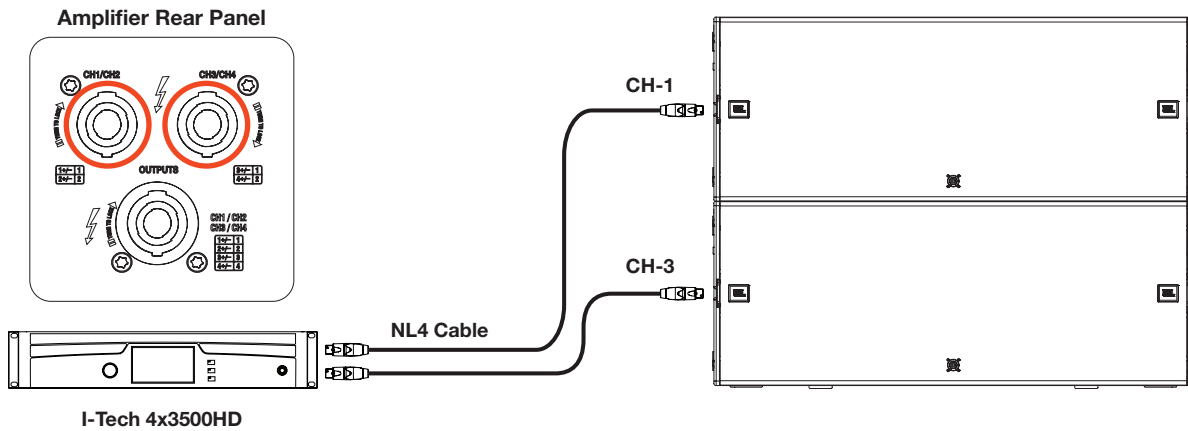

Alternatively, a cable breaking the NL4 connector out to two NL2 connectors can be used to drive one B28 each from amplifier channels 1 and 2. A four-conductor NL4 cable is employed in this arrangement, reducing cabling requirements. Amplifier channels 3 and 4 remain available for driving a full-range product, such as the VTX A8.

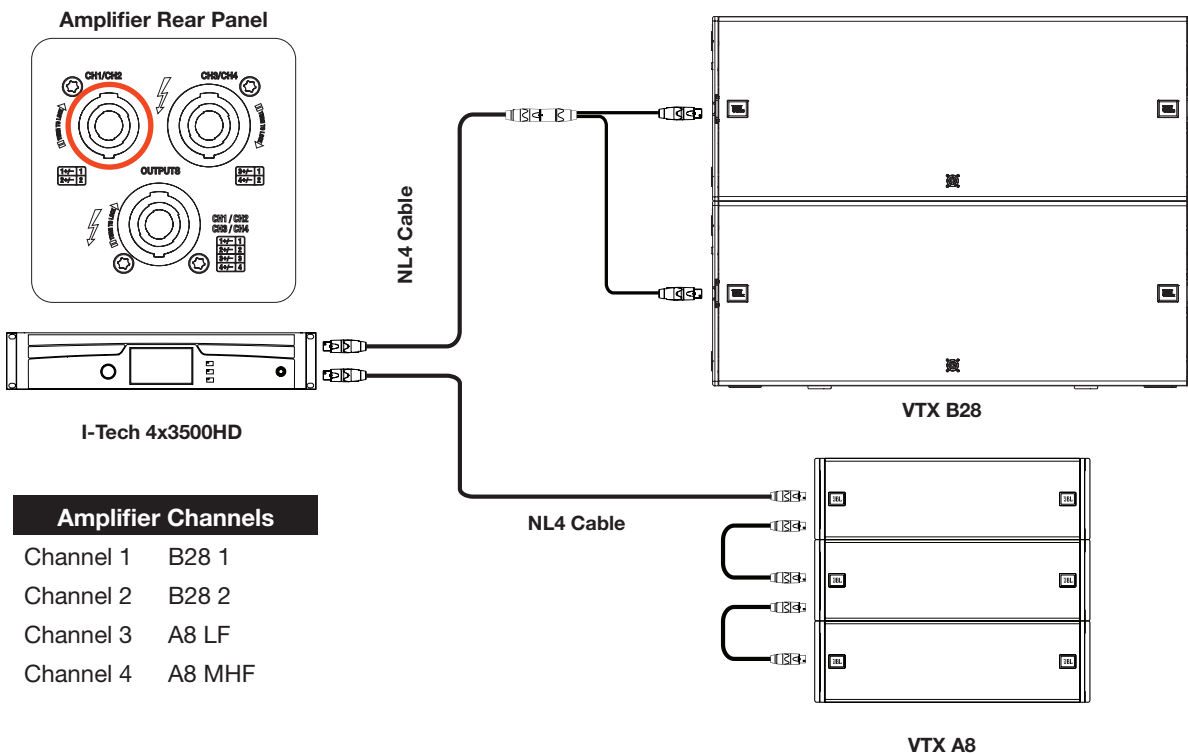

**CAUTION:** Attempting to drive more than two B28 enclosures from a single 4X3500HD is not recommended and may degrade performance and compromise long-term thermal capabilities of the amplifier.

Connecting four B28 subwoofers to a Crown 4x3500HD amplifier is generally not recommended for high SPL applications, but can be done in situations where maximum SPL is not a primary objective of the system design. This configuration requires a cable breaking an NL8 out to four NL4 connectors, allowing connection of one B28 subwoofer to each amplifier channel.

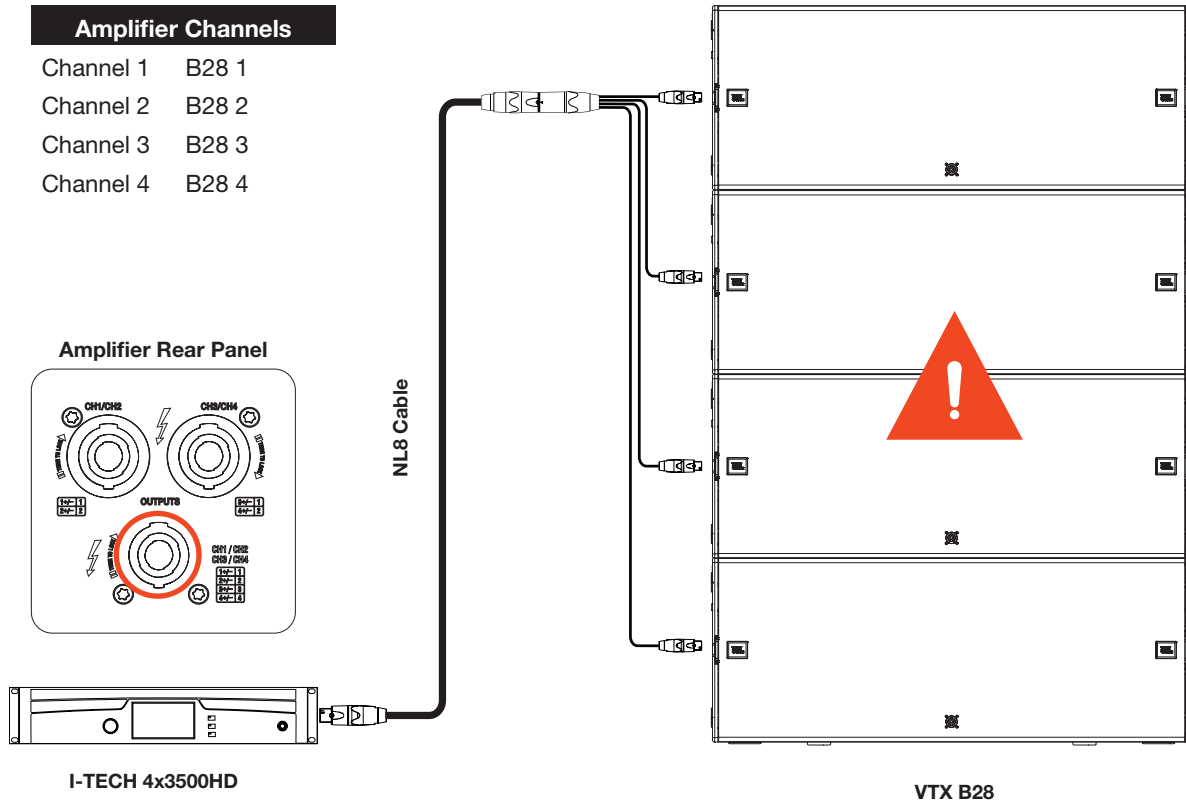

**CAUTION:** Using four B28 subwoofers on a single I-Tech 4x3500HD amplifier is NOT recommended for high SPL applications. In high SPL situations, drive one or two B28s from each four-channel amplifier. Alternatively, the two-channel I-Tech 12000HD amplifier can be used.

### 9.3 CROWN V-RACK

VTX Series systems are compatible with the Crown V-Rack 12000HD and Crown V-Rack 4x3500HD touring racks. The number of cabinets supported by each amplifier and wiring options remain the same as the Crown I-Tech examples illustrated in this document. For more information on Crown V-Rack products, refer to the V-Rack User Manuals and documentation.

## 10 - CARDIOID CONFIGURATIONS

The directivity of a subwoofer is understood to be omnidirectional, meaning that it projects energy equally in all directions. In reality, most subwoofers do exhibit some front-to-back directivity (about 1 to 3 dB, depending on the frequency), but not enough to have any meaningful impact. In some situations, the omnidirectional nature of subwoofers is desirable, but in others, a more controlled (directional) coverage is appropriate. The most common use case for directional subwoofers involves preventing excessive low frequency energy from reaching the stage. Other directional subwoofer applications include avoiding over-energizing a room with low frequency energy or minimizing noise pollution from outdoor concerts located near residential areas.

A single VTX B28 radiates omnidirectionally, but cardioid coverage can be achieved with an array of B28s in which the physical orientation of some cabinets is reversed and an appropriate amplifier preset selected.

**Example 1 : (3) VTX B28s in omnidirectional mode (forward facing)**

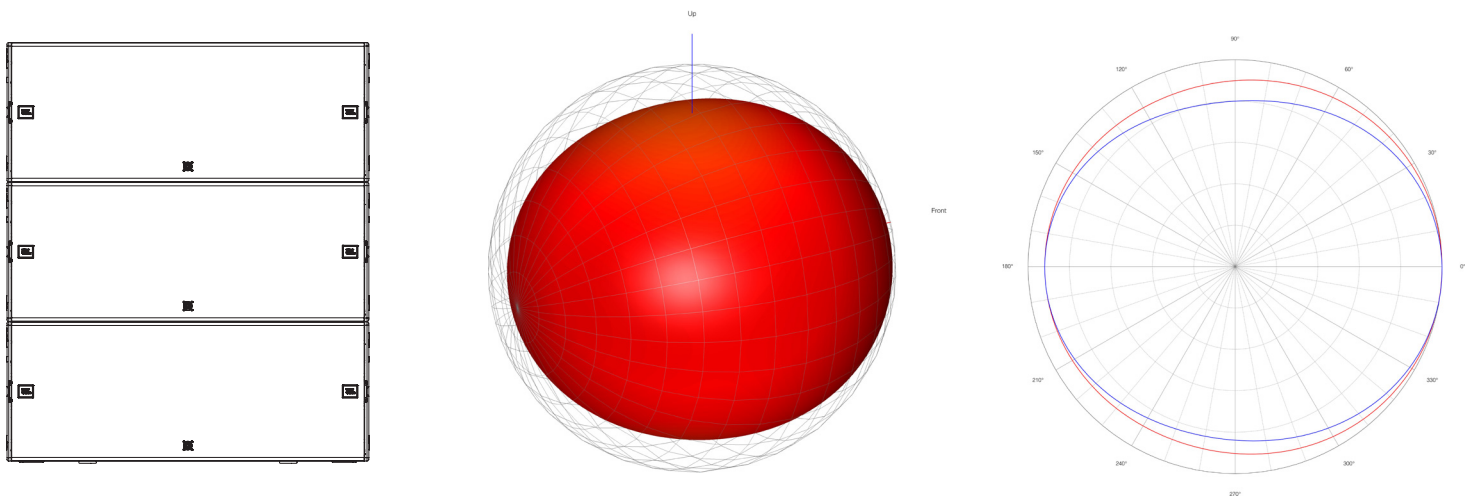

**Example 2 :(3) VTX B28s in cardioid mode (front-rear-front)**

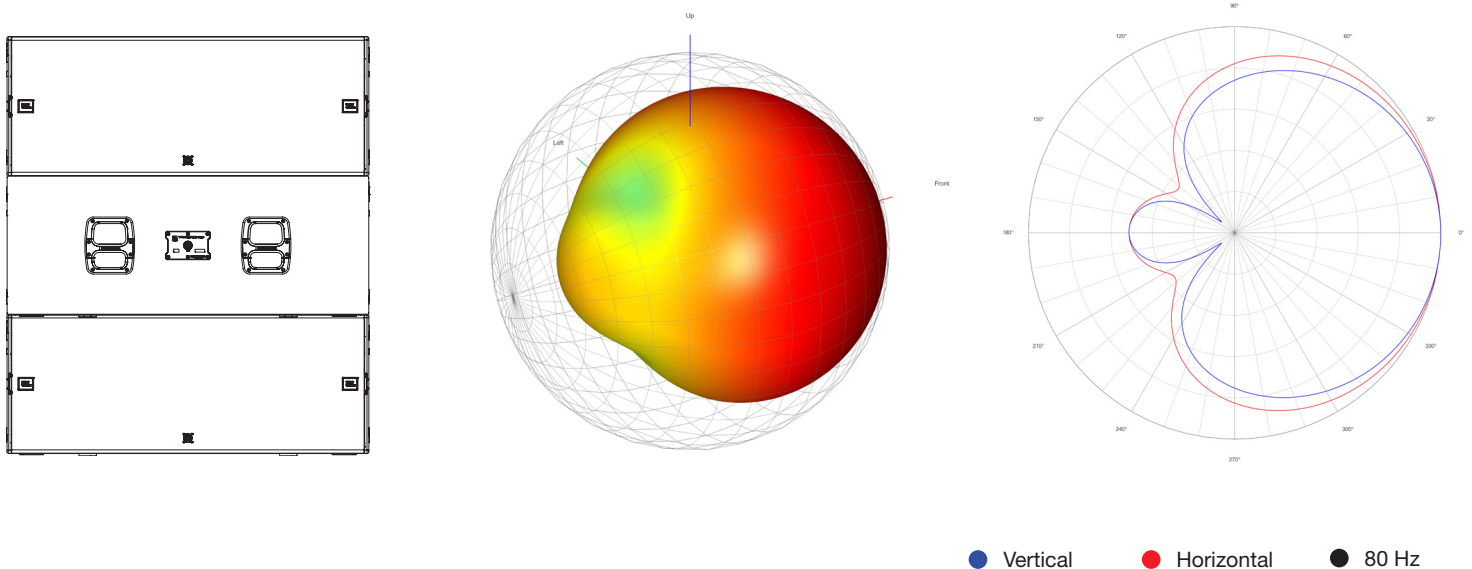

### 10.1 RECOMMENDED CARDIOID SETUPS

B28 subwoofers can be used in a number of ground stacked or flown cardioid configurations depending on available space and the number of cabinets available. Cardioid configurations are typically differentiated by the ratio of front-facing to rear-facing cabinets, the spacing between stacks, and the position of rear-facing subwoofers within the stacks. Since all configurations and ratios use the same set of amplifier presets (e.g. VTX B28 80 REAR), the amount of rear rejection is controlled by the front-to-rear-facing cabinet ratio. Lower ratios produce higher rejection, higher ratios result in lower rejection. The B28 factory presets were engineered to work with blocks having **2:1** and **3:1** ratios, with 2:1 delivering the greatest rear rejection. Subwoofers arrays designed around a 2:1 ratio can easily generate broadband rejection of 20 to 30 dB. These ratios can be considered as building blocks from which any ground stack or flown array can be built.

Example 1: 2:1 horizontal stack

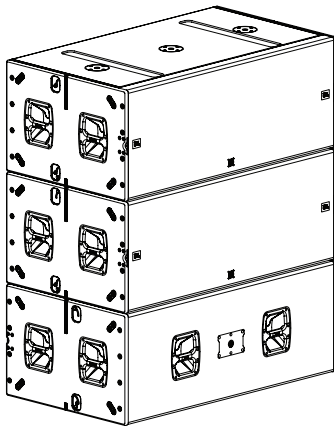

Example 2: 2:1 on-end

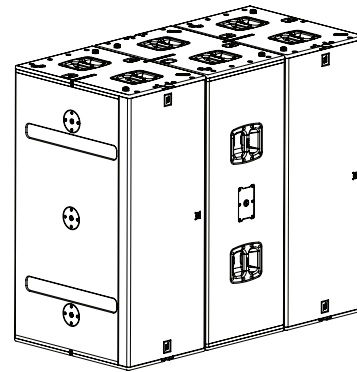

Example 3: 3:1 horizontal stack

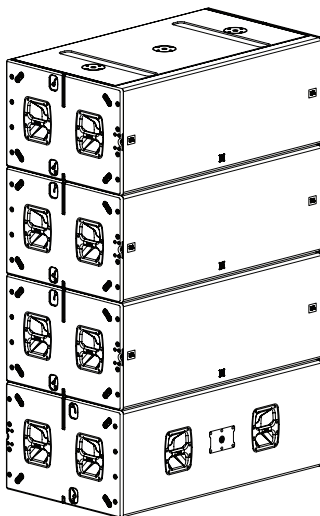

Example 4: 3:1 on-end

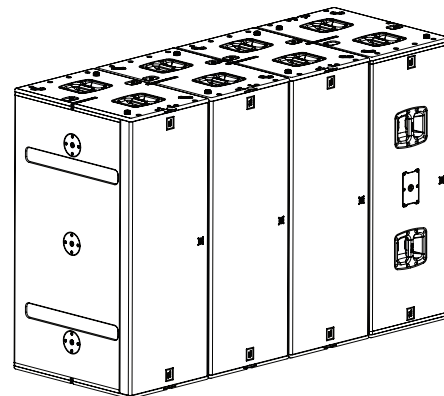

**CAUTION:** The level of the rear-facing subwoofers was carefully selected to allow B28 cardioid arrays to reach maximum SPL without dynamically compromising low-frequency directivity, and should not be adjusted.

As previously discussed, subwoofers do exhibit some front-to-back directivity, resulting in 1 to 3 dB of natural rear rejection. This is taken into consideration in the factory presets, and is the reason 2:1 is the most effective ratio. A 1:1 ratio supplies less rejection than 2:1 or 3:1, and should be avoided whenever possible. This is true for both ground stacked and suspended configurations.

Example 1: 2:1 horizontal stack

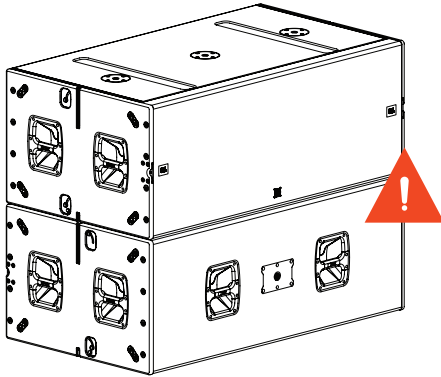

Example 2: 2:1 on-end

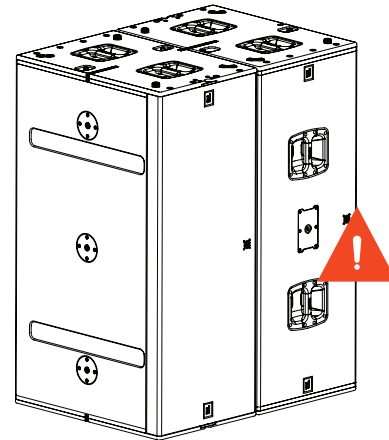

**10.2 MINIMUM SPACE BETWEEN CARDIOID STACKS**

When creating large subwoofer arrays using cardioid blocks of B28 subwoofers, a distance of at least 1.5 meters (5 feet) should be allowed between stacks to maximize rejection directly behind the array.

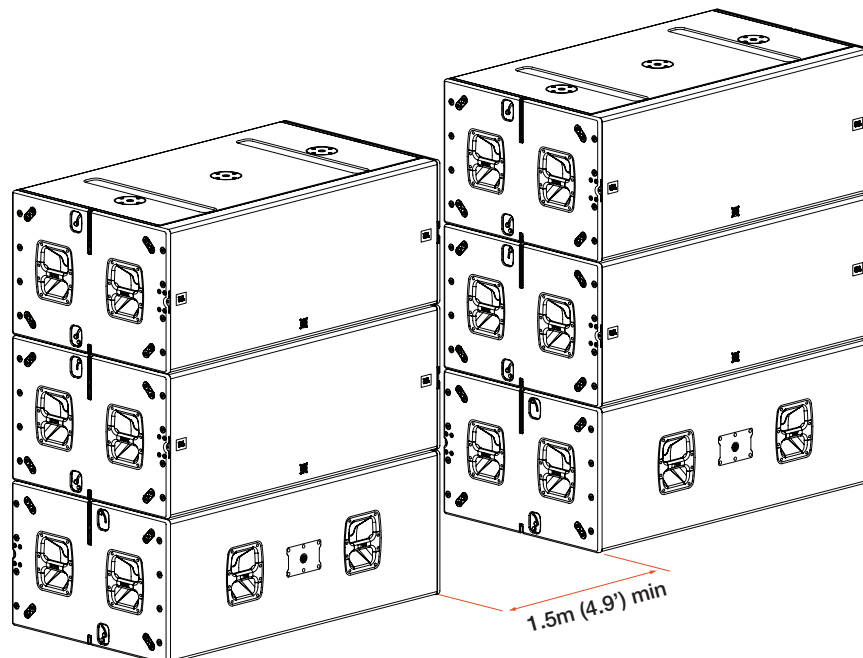

### 10.3 MINIMUM SPACE FROM A WALL

When cardioid subwoofer stacks are placed in front of a high-mass structure, like a concrete wall or stage, rear radiation patterns can be disrupted. Allow at least 5 feet (1.5 meters) of space behind the array for the cardioid effect to develop.

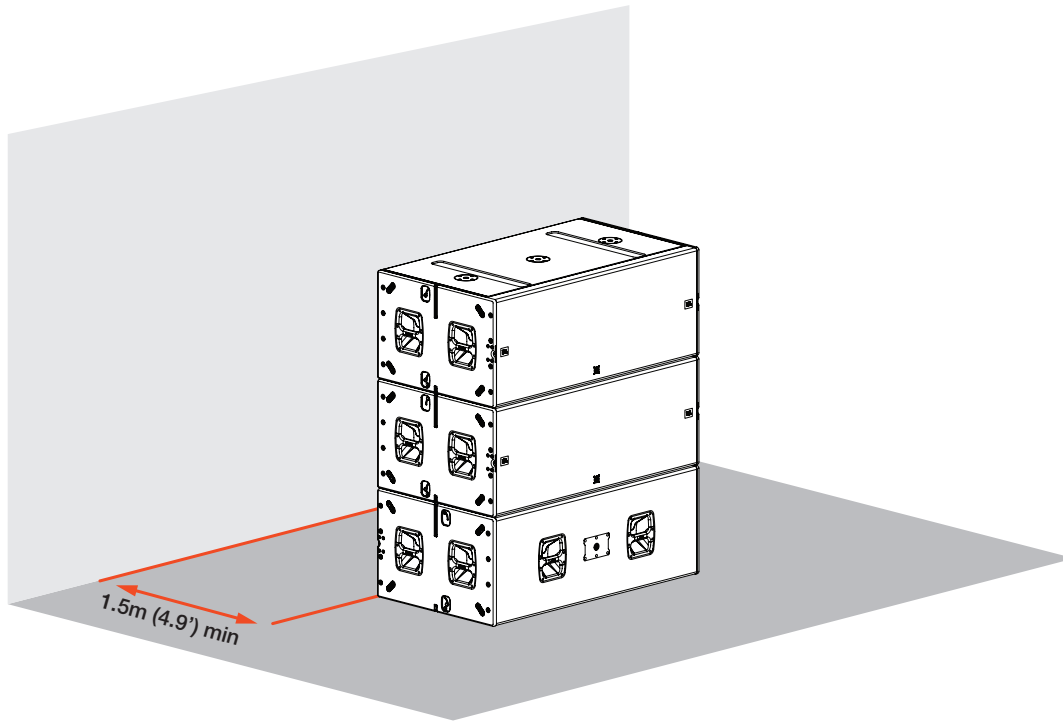



## 10.4 FLOWN ARRAY CONFIGURATIONS

Subwoofers in flown cardioid arrays should be configured in 2:1 or 3:1 building blocks and, when possible, in arrangements that are symmetrical, top to bottom. Symmetry ensures that the pattern produced by the array is axially symmetric with the physical array, allowing more predictable coverage and aiming. Asymmetric arrangements can be created, but should always be modeled first in LAC-3 to ensure that the cancellation areas in the coverage fall outside of the audience areas.

Example 1: (6) subwoofer flown array in 2:1 blocks

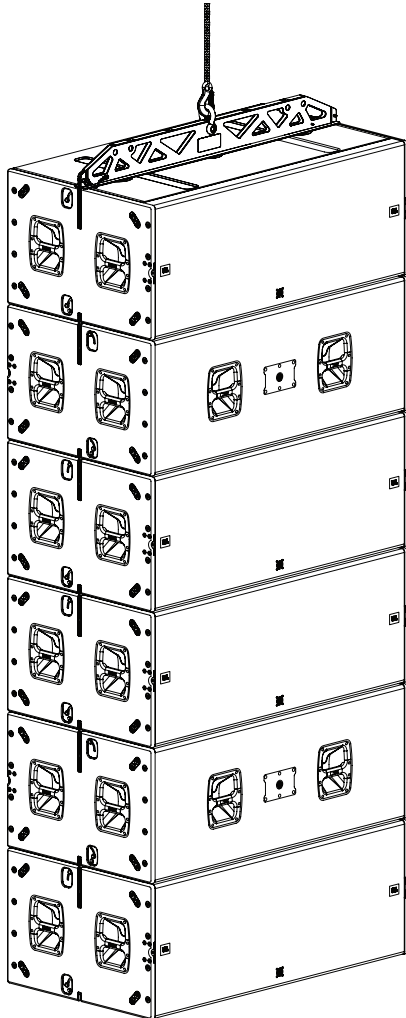

Example 2: (8) subwoofer arrays in 3:1 blocks

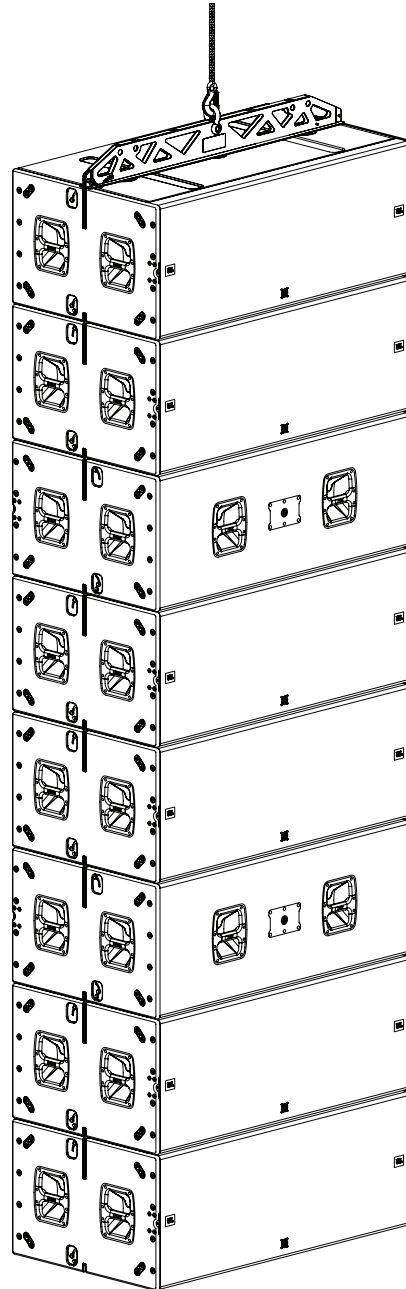

In some cases, asymmetric arrays are unavoidable, especially when the arrays are configured in blocks of four cabinets. In these cases, coverage tends to be biased towards a specific direction, but strategic placement can help shape coverage to the specific needs of a venue. Use LAC-3 to design such arrays.

## 1.1 - CARDIOID PRESETS IN PERFORMANCE MANAGER

Performance Manager software allows selection of the appropriate factory preset for any subwoofer configuration. Each amplifier channel can run its own preset, enabling implementation of the configuration and layout needed for each situation.

### STEPS:

- 1 Navigate to the “DESIGN” mode and then to “Add Amps & DSP”.
- 2 Using the “Device View” selection control, switch the view to “Orientation.”
- 3 Use the “R” (REAR) button to reverse the orientation of a cabinet in Performance Manager.
- 4 Switch the “Device View” back to “Bandpass” view.

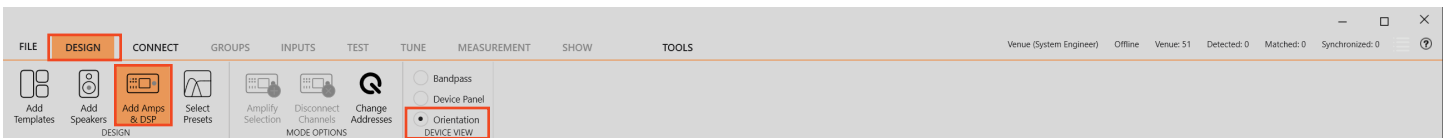

Once orientation has been selected, Performance Manager assigns the appropriate factory preset to the amplifier channel assigned to the selected B28. Cardioid arrays created in the Line Array Calculator application can be imported into Performance Manager with all parameters maintained.

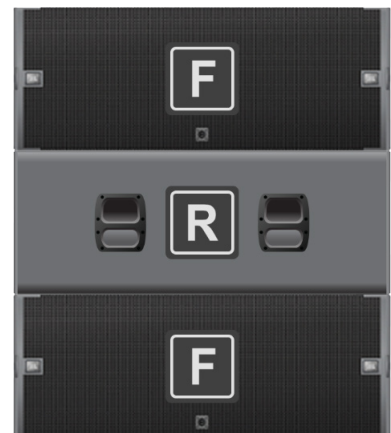

**TIP:** The latest version of Performance Manager and Line Array Calculator can be either downloaded directly from [www.jblpro.com](http://www.jblpro.com) or by choosing the Check for Updates menu command from within the application.

## 12 - TESTING THE VTX B28

As with all speakers, the VTX B28 must be checked and maintained periodically in order to assure long-term performance. While the system is designed to exhibit the utmost reliability, ensuring optimal performance for years to come requires confirming that the B28 is operating within specified tolerances. Below are two methods of checking and verifying proper transducer performance in a VTX B28 system.

### 12.1 USING A DMM (DIGITAL MULTI METER)

This method is best suited for when the speaker system can be tested in the shop. A DCR (DC resistance) test with a multimeter can give a very accurate reading of whether transducers are properly wired and operating within standard tolerances. This test is appropriate only for individual enclosures, not groups of cabinets.

With the B28 unconnected from any amplifier, set a DMM to the resistance ( $\Omega$ ) setting and place the probes across the Pin1+/- Outputs. Record the values indicated on the DMM for each pair of leads and refer to the chart below to determine if the DCR readings are within tolerance.

B28		
	DCR	Tolerance
Both woofers functioning	2.15 $\Omega$	+/- 0.5 $\Omega$
One woofer open	4.1 $\Omega$	+/- 0.5 $\Omega$
Any driver shorted	0.2 $\Omega$	-

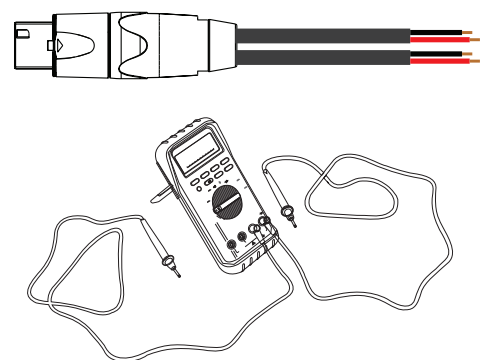
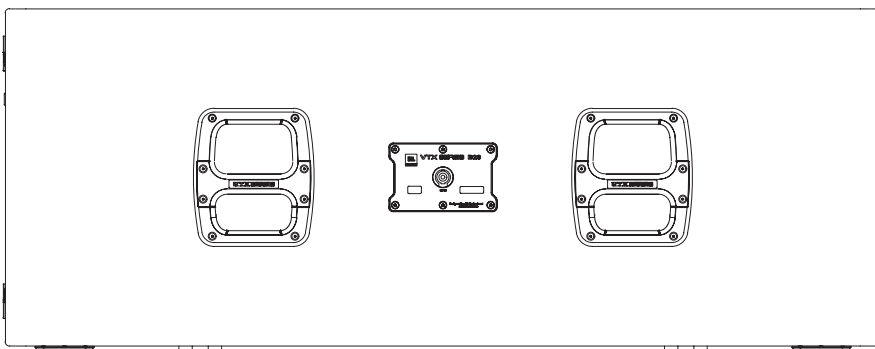

#### Notes:

- The DCR numbers listed above assume the transducers are at room temperature. If measurement is taken right after use when the transducers are warm, readings may vary. For best results, test the speakers cold.
- The DCR value of a transducer gives an accurate representation of its electrical state. Mechanical defects will not be indicated by this test. Refer to the VTX B28 Service Manual for instructions on performing a rub-and-buzz test using a sine wave generator.

## 12.2 USING PERFORMANCE MANAGER

When in the field, Performance Manager's **Test System Mode** can be used to test VTX systems. This method is quick, and especially useful for determining whether all speaker cables, including cabinet-to-cabinet NL jumpers, are properly functioning.

To perform the test, Performance Manager uses the I-Tech HD's built-in noise generator, in conjunction with the amplifier's capabilities to sense voltage and current draw, to generate a nominal load impedance reading for each amplifier output channel. Since broadband pink noise is used as the test stimulus, the returned value is considered to be an average impedance value, which will differ from the resistance values given earlier in this document, that are taken using DC resistance.

### STEPS:

- 1 To start the test make sure Performance Manager is online and connected to the devices.
- 2 Navigate to the **TEST** tab and make sure all speakers are muted
- 3 Switch the Noise Generator to the ON position and change the level to between -30 and -10 dB. Levels lower than -30 dB may not be sufficient to trigger a reading.
- 4 Unmute the speaker to start the measurement. The measured value is displayed on the speaker icons.

## 12.3 PERFORMANCE MANAGER READINGS

The measurements below show the expected impedance values for B28 cabinets, taken at room temperature with a cable length of 25 meters (82 feet). Acceptable tolerance is +/- 0.5 ohms.

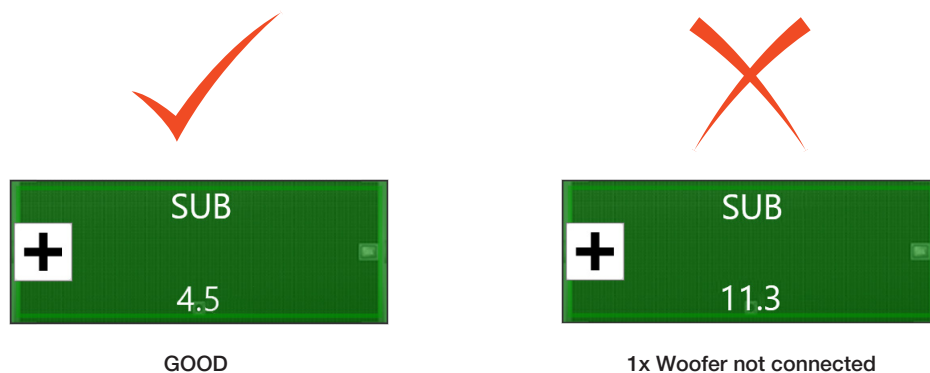

The measurements recorded by Performance Manager are susceptible to drift based on variables such as temperature, cable length, wire gauge, and usage conditions. Parameter variations such as temperature will be common across all B28 enclosures in use, so all B28 subwoofers in a system should measure similarly. An enclosure measuring significantly different than others (by as much as several ohms) indicates something wrong with that enclosure.



**TIP:** The Performance Manager measurement uses an averaging algorithm in the background to generate a stable and reliable impedance value. Measurements take time to stabilize. Continue running the measurement until the displayed value settles.

## 13 - SPECIFICATIONS

### 13.1 VTX B28

#### SYSTEM

**Frequency Range (-10 dB) :** 25 Hz - 80 Hz (Preset: VTX B28 80)

**Coverage Pattern Options<sup>1</sup> :** Omnidirectional or Cardioid

**System Input Power Rating<sup>2</sup> :** 2600W Continuous (IEC/100 hour)

**Maximum Peak Output<sup>3</sup> :** 141 dB (Preset: VTX B28 80)

**System Amplification :** Crown I-Tech 12000HD  
Crown I-Tech 4x3500HD

**Required Amplifier Channels:** (1) channel (SUB)

**Number of Cabinets per Amplifier**

IT-12000HD : (2) VTX B28

IT-4x3500HD<sup>4</sup> : (2) VTX B28

**System Impedance<sup>5</sup> :** 4 ohms

#### TRANSDUCERS

**Low Frequency :** (2) JBL 2288H-M, 18 in diameter, dual 4 in diameter voice coil, Neodymium Differential Drive

#### ENCLOSURE

**Construction :** 18 mm 13-ply and 12 mm 9-ply Finnish birch plywood, Black DuraFlex™ finish, four integral recessed handles

**IP Rating<sup>6</sup> :** IP55 (IEC 60529)

**Suspension :** High-grade steel with anti-corrosion coating, captive suspension plates, captive pins, spring-loaded mechanism, two-step safety lock

**Grill :** Powder coated 1.8 mm (14-gauge) hex-perforated stainless steel with acoustically transparent black cloth backing

**Connectors**

**Type :** Neutrik® speakON® NL4 (one at the rear and one at the front)

**Pin Assignments :** Pins 1 ± active | Pins 2 ± not connected

**Dimensions (H x W x D) :** 508 mm x 1324 mm x 750 mm  
20 in x 52.1 in x 29.5 in

**Net Weight :** 87 kg (191.8 lbs)

**Footnotes:**

1: Based on speaker preset selection and cabinet orientation/configuration.

2: IEC Standard: IEC shaped noise with 6 dB crest factor based on nominal impedance and a duration of 100 hours. Continuous is defined as 2x RMS.

3: Peak, unweighted SPL, measured under **half-space** conditions at 1 meter using broadband pink noise with a 12 dB crest factor and specified preset.

4: For more information on how to power B28 subwoofers using I-Tech 4x3500HD amplifiers refer to the VTX B28 User Manual.

5: Nominal impedance within the stated frequency range of the product. Minimum impedance is 5.6Ω at 150 Hz.

6: Front face at 0 degrees or greater down angle to allow the cabinet to drain water. Suspension components fully weather rated for indoor or covered outdoor conditions where humidity is nominally under 50% and not local to bodies of corrosive materials. Unused speakON connectors must be sealed using silicone to protect against water and moisture.

JBL continually engages in research related to product improvement. Some materials, production methods and design refinements are introduced into existing products without notice as a routine expression of that philosophy. For this reason, any current JBL product may differ in some respect from its published description, but will always equal or exceed the original design specifications unless otherwise stated.

## 14 - ACOUSTIC MEASUREMENTS

### FREQUENCY RESPONSE

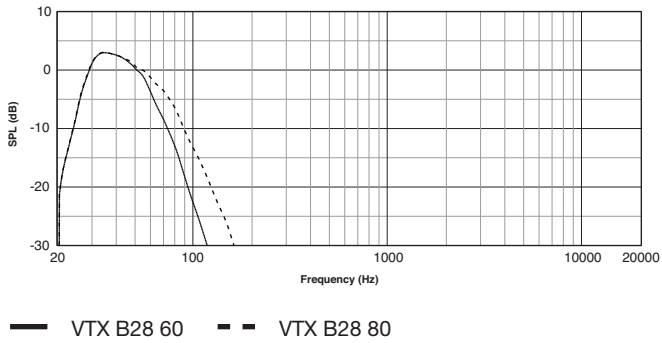

## 15 - DIMENSIONS

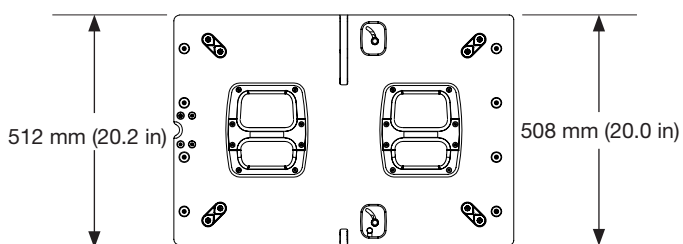
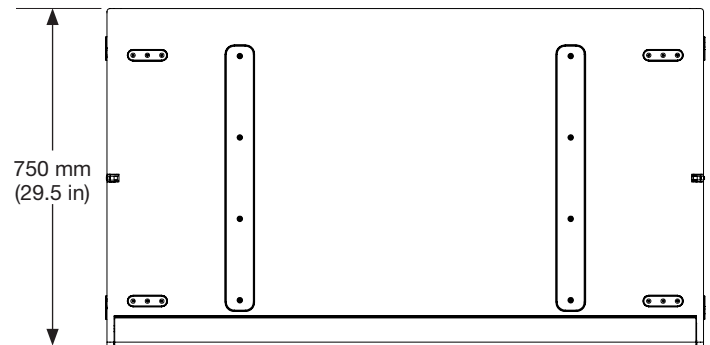
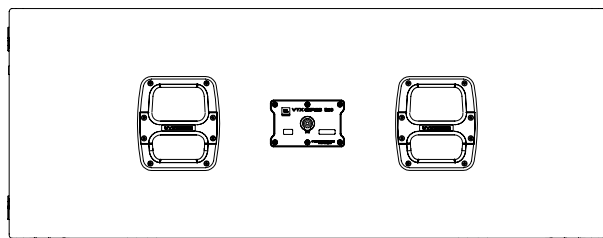
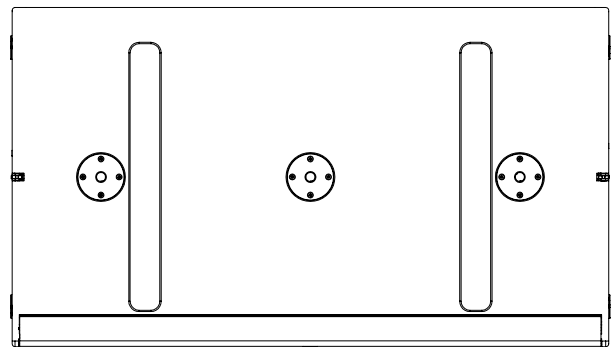
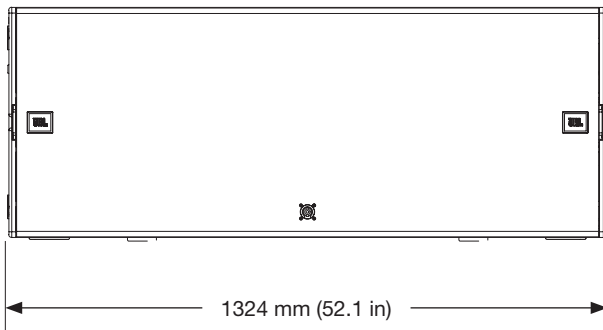

## 16 - CONTACT INFORMATION

### UNITED STATES OF AMERICA

#### HARMAN Professional Solutions

8500 Balboa Blvd.  
Northridge, CA 91329  
USA  
+1 (844) 776-4899  
[www.jblpro.com](http://www.jblpro.com)

#### U.S.A. Technical Support

+1 (800) 852-5776  
[HProTechSupportUSA@Harman.com](mailto:HProTechSupportUSA@Harman.com)  
[www.jblpro.com](http://www.jblpro.com)

### PROFESSIONAL CONTACTS, OUTSIDE THE U.S.A.:

Contact the JBL Professional distributor in your area. A complete list of JBL Professional international distributors is provided at our U.S.A. website: [www.jblpro.com](http://www.jblpro.com)

#### HARMAN Professional EMEA

Westside  
London Road  
Hemel Hempstead  
HP3 9TD  
United Kingdom  
[www.pro.harman.com](http://www.pro.harman.com)  
[www.jblpro.com/support](http://www.jblpro.com/support)

#### HARMAN Professional APAC

108 Pasir Panjang Road  
#02-08 Golden Agri Plaza  
Singapore 118535  
+65 6870-5000  
[www.pro.harman.com](http://www.pro.harman.com)  
[www.jblpro.com/support](http://www.jblpro.com/support)

#### HARMAN Professional China

20F, China Merchants Port Plaza, #1  
Gongye 3rd Road, Shekou, Nanshan  
Dist.  
Shenzhen, 518067, China  
400 166 7806  
[www.harman.com/China](http://www.harman.com/China)

#### China In-Country Support

[ChinaPRO.Service@harman.com](mailto:ChinaPRO.Service@harman.com)

#### HARMAN Professional India

Prestige Technology Park  
Jupiter 2A Block, 4th Floor  
Marathahalli Ring Road  
Bangalore 560103, India  
+1 (800) 208-8880  
[www.harman.com/India](http://www.harman.com/India)

#### HARMAN Professional Brazil

Br386, Km435 92480-000  
Nova Santa Rita Rs  
Brazil  
+55 51 34794000  
[www.harman.com/Brasil](http://www.harman.com/Brasil)  
[www.jblaudio.com.br](http://www.jblaudio.com.br)

#### India In-Country Support

[www.harman.com/india/india-service-center](http://www.harman.com/india/india-service-center)

#### Brazil In-Country Support

[tecnica@harman.com](mailto:tecnica@harman.com)

